



ND

POT, PACK AND TRAY DENESTER

## MACHINE DESCRIPTION

Electropneumatic machine, with modular composition, to denest trays, shuttle trays, outer trays and for the introduction of pots and packs.



*ND 4300 with 3 mov. denester for outer trays followed by n. 3 denesters for pots.*



Video



Video



Video

## EXAMPLES OF MACHINE COMPOSITIONS

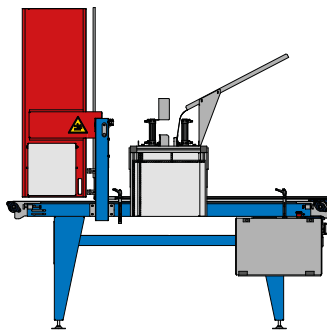

ND 2300 with 2 mov. denester for polystyrene trays and 3 mov. denester for thermoformed packs.

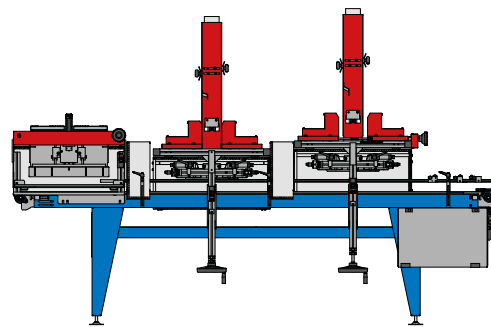

ND 3300 with 3 mov. denester for barquette and double denester for godet.

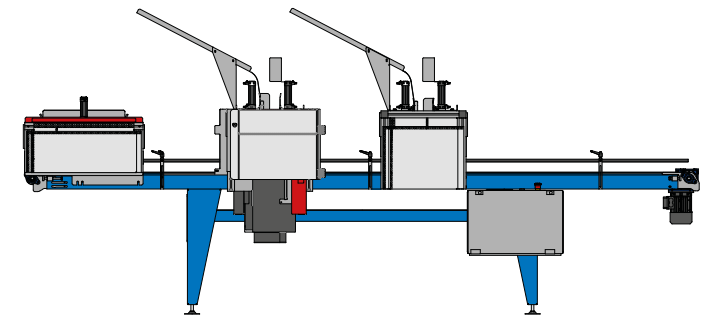

ND 4300 with 3 mov. denester for thermoformed trays, 3 mov. denester for thermoformed packs and ETC2 labelling machine, 3 mov. denester for pots.

## TECHNICAL SPECIFICATIONS

- Machine controlled by PLC and data display with touch-screen monitor.
- Control with 4,5" monochromatic touch-screen (labels from PC) or 5,7" monochromatic (labels from touch-screen).
- Hourly production according to the denester mounted on the machine and to the type of tray to distribute.
- Air consumption according to the installed denesters.
- Alarm prior to pots and trays finishing.
- Equipped from 1 to 6 denesters.

## ACCESSORIES

- 2-3-4 mov. **denesters**, for **polystyrene, thermoformed, injection** and **outer trays**.
- 3 mov. **denester for barquette**.
- **Denester for godet**.
- **ETCF** and **ETC2 labeller**.
- **Wheels** for transport.
- Empty tray **stacks feeding belt**.
- Pneumatic **balance stacker**.

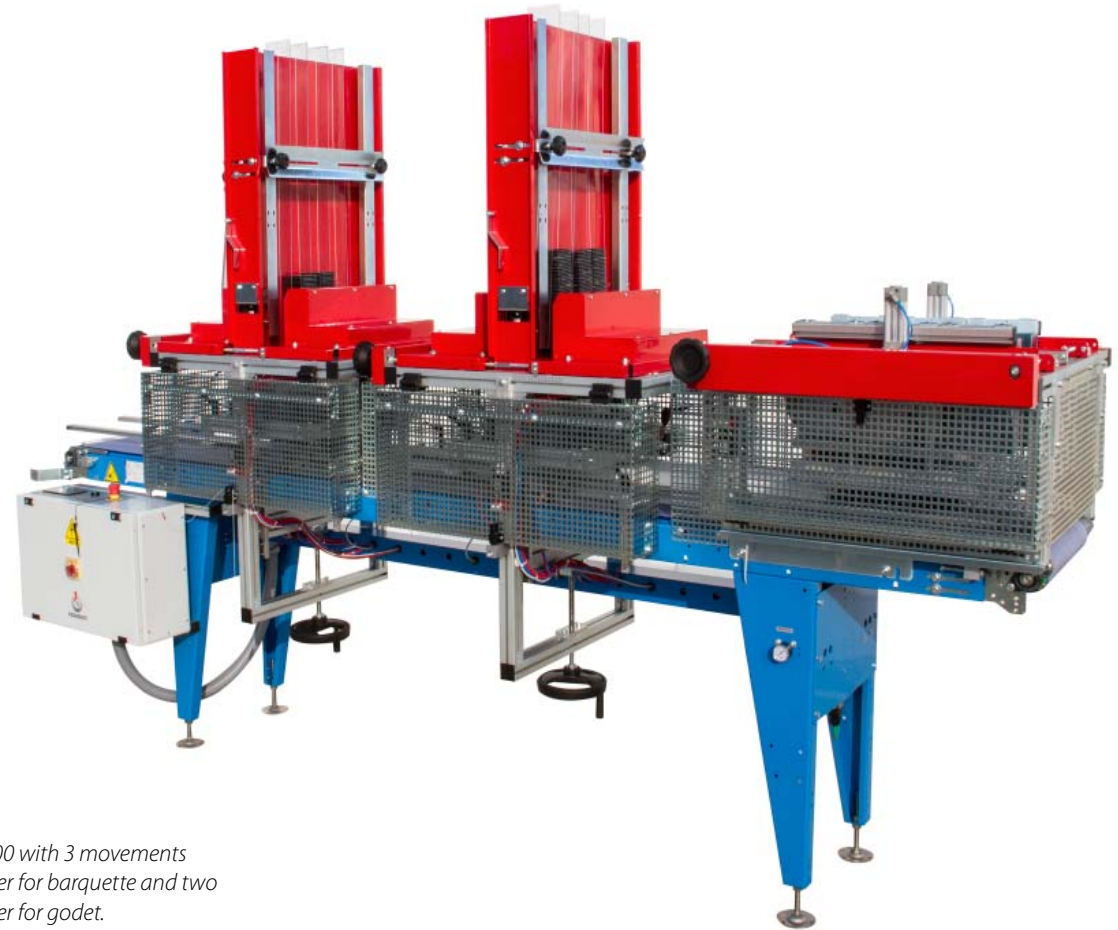

*ND 3300 with 3 movements  
denester for barquette and two  
denester for godet.*

## DETAILS



Expanded polystyrene outer tray denester with **label application** and introduction of **thermoformed packs**.



Destacking of the **thermoformed tray** with label application.



Destacking of **thermoformed transport tray** and **pot introduction**.



Destacking of thermoformed outer tray and **hydroponics growing pots introduction**.