

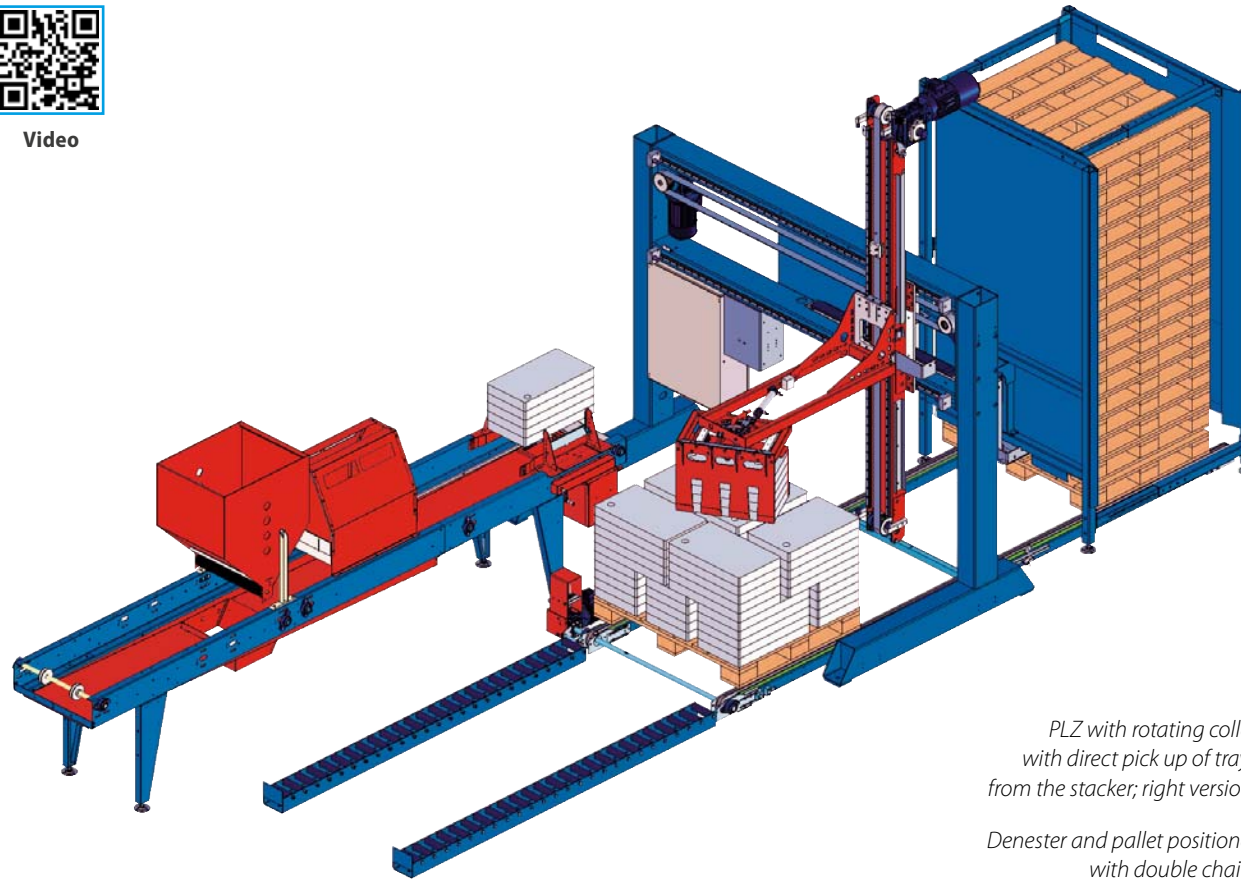

# PLZ PALLETIZER



Video



*PLZ with rotating collet  
with direct pick up of trays  
from the stacker; right version.*

*Denester and pallet positioner  
with double chain.*



The **rotating collect** enables to place the trays on the pallet **in order to optimize space**.

## MACHINE DESCRIPTION

Palletizer for trays or crates, fast and easy to program.

TECHNICAL DATA	M.U.	PLZ
HOURLY PRODUCTION	cycle/hour	240
HEIGHT TO PALLETIZE (max)	mm	2000
TRAYS DIMENSIONS (max)	mm	700x500
PALLET DIMENSIONS (max)	mm	1300x1300
INSTALLED POWER	kW	6
AIR CONSUMPTION (max)	l/min	55

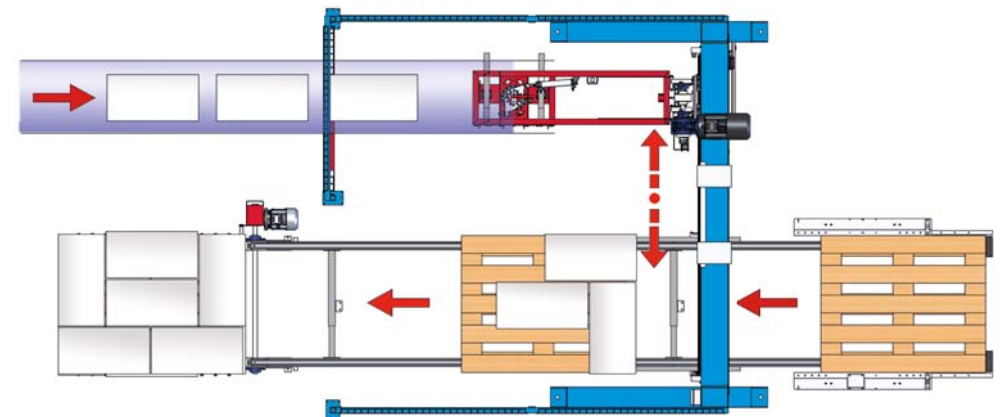

## TECHNICAL SPECIFICATIONS

- Easy programming for the operator with 5,7" colour touch-screen panel.
- Automatic lubrication with tank on linear bearings.
- Machine weight: according to its composition.
- Available in right and left solutions.





Palletizer for trays: collet on **loading phase**.



Unloading phase: **trays stacked on the pallet**.



Palletizer for **crates with blocks**: collet on **unloading phase**.

EXAMPLE OF TRAYS DISPOSITIONS ON PALLET AND ON CC TROLLEYS

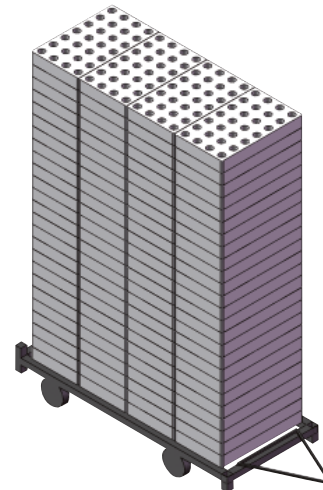
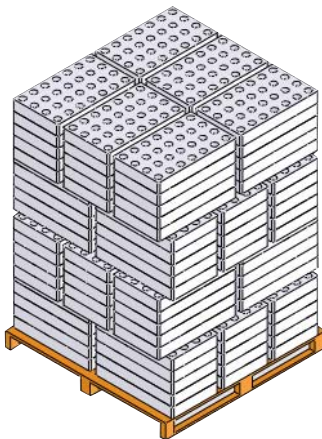
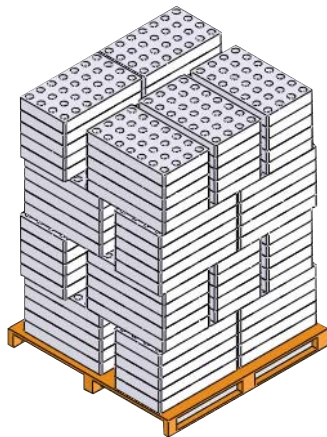
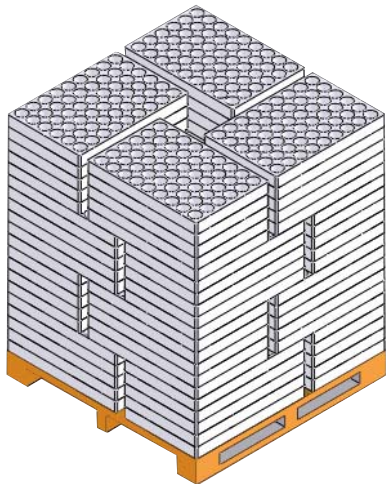

ACCESSORIES

- **Pallet unloading** from the **opposite side** of pick up.
- **Rotating** collet.
- **Multiple** collet.
- **Pallet denester**.
- **Positioner belts** for loading.