

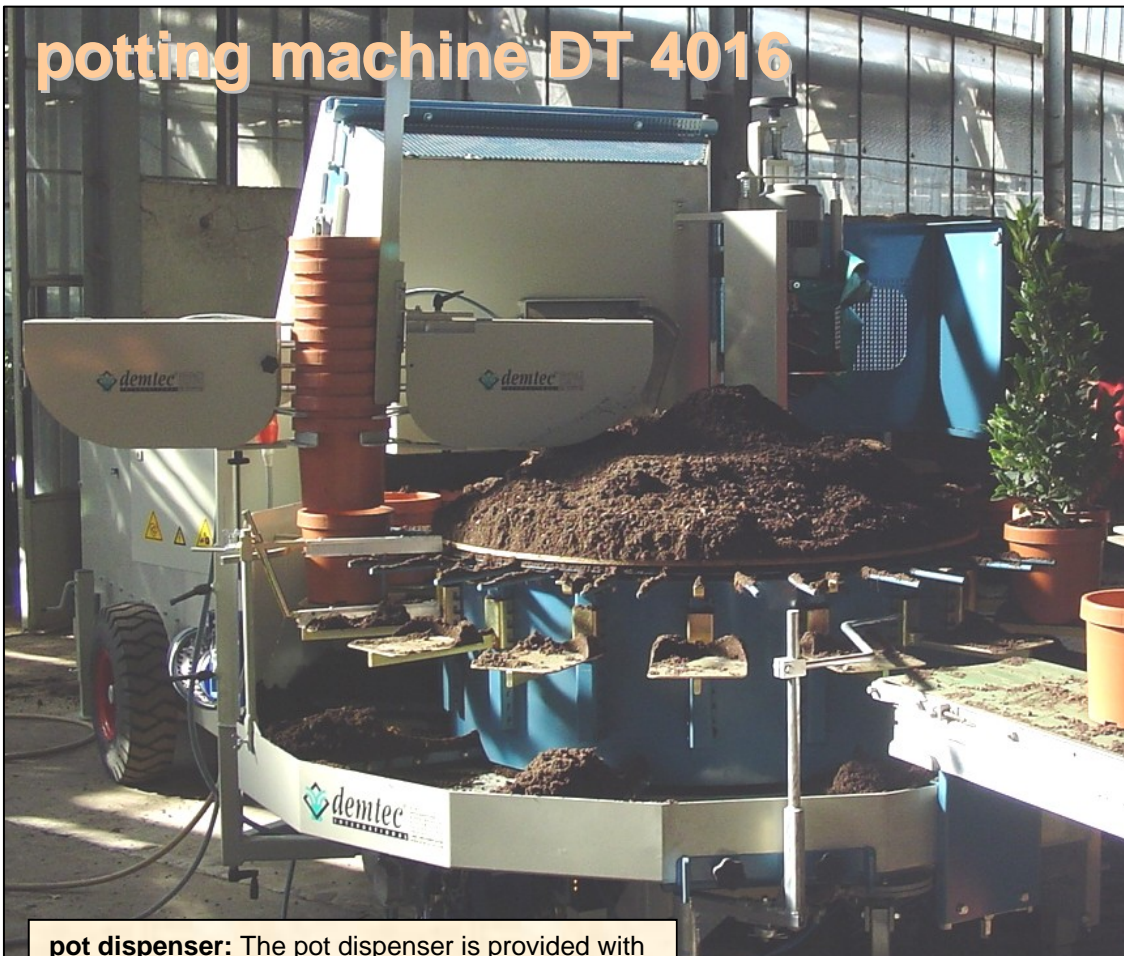

## potting machine DT 4016



Demaitere Ltd. is a machine manufacturer specialised in plant potting automation.

Based on a long experience, recently two new potting machines were added to our range. These are especially developed for working with large pots.

The machines are adapted to the needs of container nursing: tolerant soil supply, space for big containers, adjusted pot dispenser and a powerful drilling motor.

**pot dispenser:** The pot dispenser is provided with 2 strong cylinders (pushing power: 120 kg) that separate the pots for 6 cm. Even used pots that stick to each other by remaining dirt or moisture can be destacked.

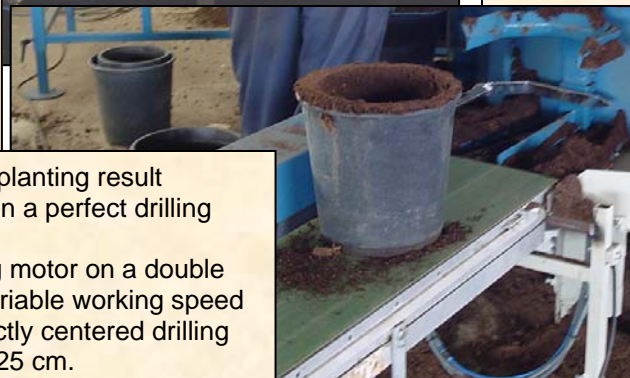

**drilling:** A good planting result depends mostly on a perfect drilling hole. A powerful drilling motor on a double guide and with variable working speed guarantees perfectly centered drilling holes upto diam. 25 cm.

**soil elevator:** the soil elevator system processes all types of soil. A detection system is provided around the elevator chain that stops the soil supply if there is too much soil in the machine. The drilled soil is transported by means of a conveyor into the soil bin.

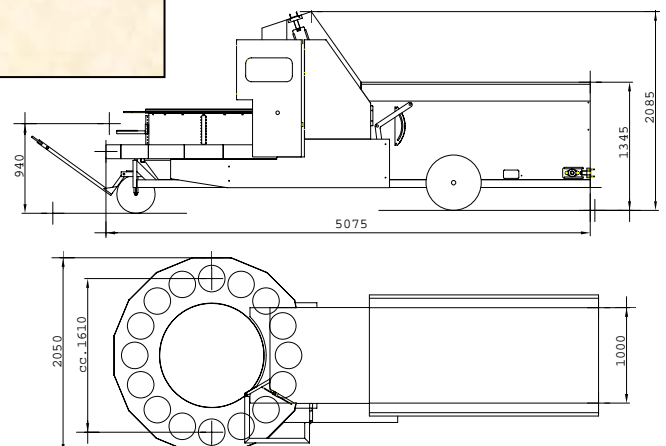

The potting machine **DT 5016** is in every respect a potting machine with exceptional qualities. The machine is perfectly equipped for potting large and heavy pots up to diam. 42 cm (standard trees, laurels, palms, ...).

A comfortable working position is generated by the low working height.

The standstill time of the machine can be individually set in relation to the working speed so that potting is completely controlled: machine can be stopped longer for plants that are difficult to process compared to "easy" plants.

## potting machine DT 5016



The up and down going movement of the drill is frequency controlled. The powerful motor enables drilling holes with maximum diam. 32 cm. The machine can be set in such a way that for instance a plant out of a 32 cm pot can be potted into a 40 cm pot. The pot dispenser is obviously adjusted for such containers. The number of pots on the potting ring is determined by the space that the plants require, multiple combinations are possible.



The pot holders are taylormade to secure maximum support.

Optionally, the ring can receive extra soil by means of an opening in the front .

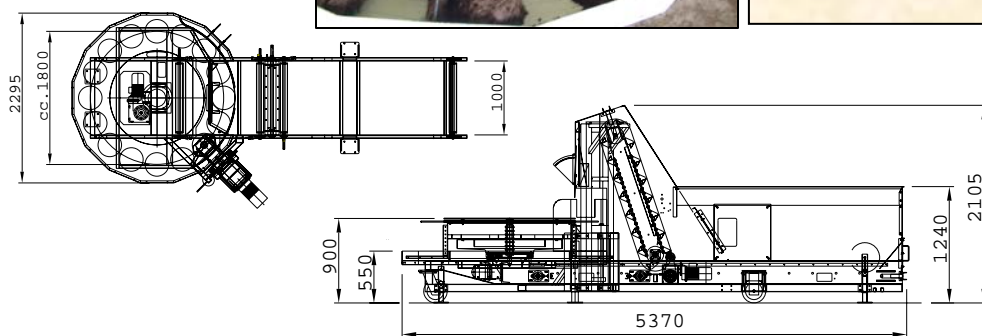

	<b>DT 4016</b>	<b>DT 5016</b>
diameter potting ring	2.050 mm	2.293 mm
maximum pot diameter	380 mm	420 mm
height soil elevator	1.750 mm	1.785 mm
load drill motor	1,1 kW	tot 3 kW
maximum drill diameter	diam. 250 mm	diam. 320 mm
adjustable speed drilling head	✓	2 speed
downwards movement drill	fixed speed	adjustable speed
contents soil bin	3.000 – 5.000 liter	3.000 – 5.000 liter
soil detection system	✓	✓
drive potting ring	worm gear drive	direct drive
working speed (16 pots ring)	600 – 2.400 pots per hour	180 – 720 pots per hour